

Carbon Fiber Seat Heater Installation Manual

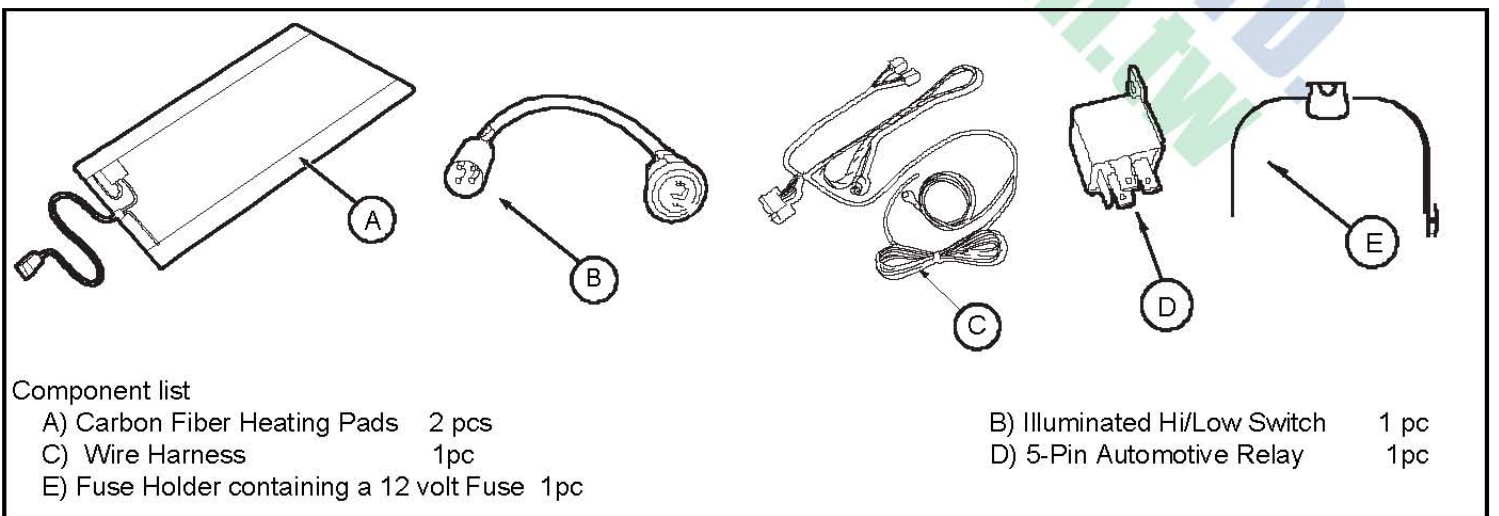
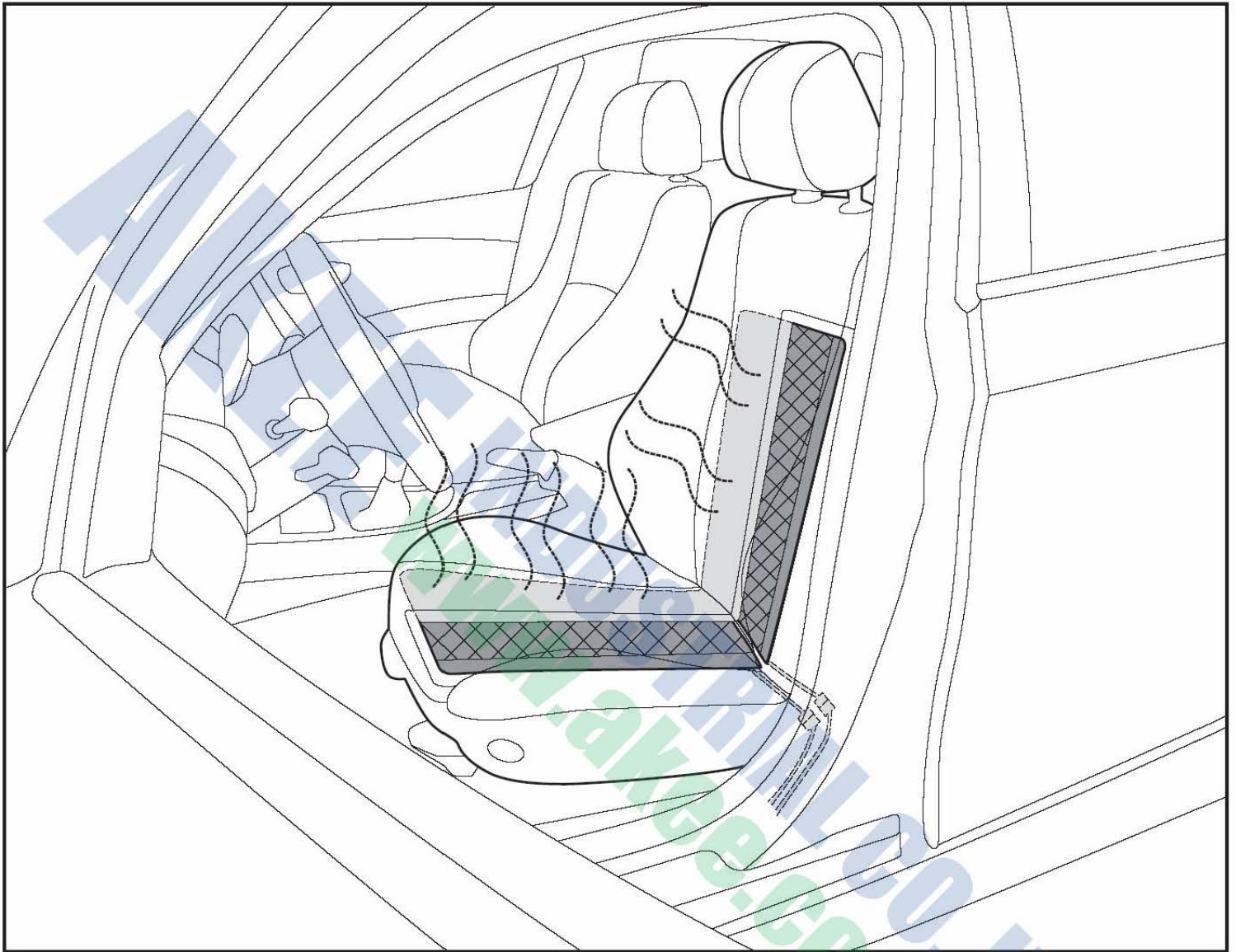

Component list

A) Carbon Fiber Heating Pads 2 pcs

C) Wire Harness 1pc

E) Fuse Holder containing a 12 volt Fuse 1pc

B) Illuminated Hi/Low Switch 1 pc

D) 5-Pin Automotive Relay 1pc

General safety advice

A

a = min. 250 mm
a = min. 9 1/32"

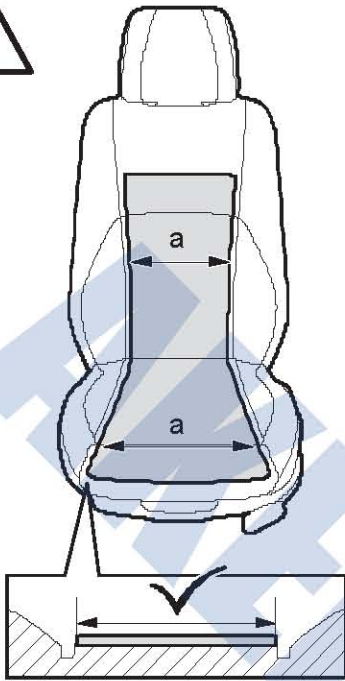

B

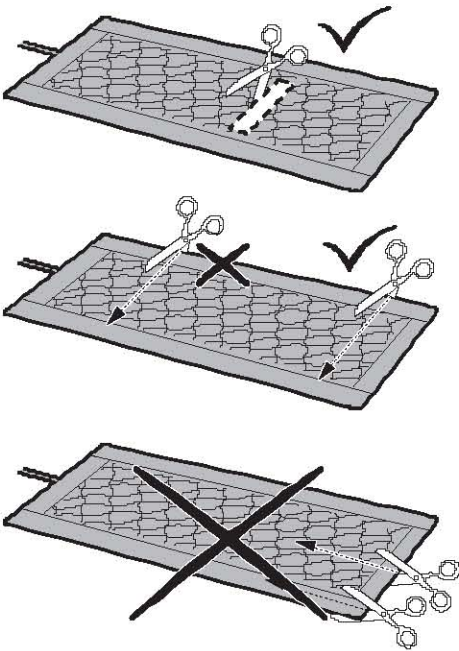

Warning:

Seat heaters must not be installed in vehicles that will be used by paraplegic or other occupants who cannot sense heat. Customers must notify the original installer if the vehicle is sold to a third party.

A. It is impossible to install Peak Seat Heater kits whenever:

- a_ The seat covers are adhered to the seat's foam padding, or
- b_ The seat's longitudinal listing channels are spaced less than 10" apart.

B. The battery terminals should be disconnected in advance, before working on the vehicle's electrical circuits. The security codes (radio, navigation system, etc.) should be noted.

C. The seat cover and seams should remain unmodified for seats with side air-bags. The heating elements are only allowed to be fitted in the middle of the seat. Please refer to the manufacturer's vehicle manual.

D. Refer to owner's manual for seats with integrated seat belts or occupant detection sensors for air bags.

E. The heating elements are only allowed to be installed by qualified professional installation personnel. They must be knowledgeable about electronic systems and upholstery. Improper installs can adversely affect the system's reliability and risk overheating.

F. Use original kit components only.

G. The heating elements must be secured and mounted free of folds and creases. Heating elements must not be damaged during the installation. Avoid exposure to any sharp object that could compromise the integrity of the heating element. It is imperative for durability and the system's reliability that the complete heating element is positioned correctly. Any modifications to the seat's components, which affect the heating elements or come into contact with them, can influence its durability and reliability.

H. The heating element is only allowed to be operated at $+12\text{ V} \pm 3\text{ V}$. It should ideally be connected to the onboard power supply via ignition voltage and the protective fuse should ideally be put in an empty bay in the fuse box. The seat heating unit should be protected by a fuse with a maximum rating of 12 amps.

I. The heating elements are only allowed to be modified as described in these installation instructions, except width which is not allowed to be altered in any way.

J. The wire harness is not allowed to be modified. Ensure that the wire harness is secured and fastened properly. The wire harness must be routed properly so the seat can move freely without any difficulty. Contact with sharp edges, bending or pulling of wire must be avoided, in order to prevent the wire harness from being damaged. The onboard main supply and the wire harness cross-section must be adapted to the extra current loads if necessary. Refer to the vehicle's wiring diagram for additional information.

K. The foam padding must be clean and free from separating agents, grease, silicone, dust and oil before the heating mats are secured to it. The full adhesive strength will only be attained if sufficient pressure is applied during the installation and when an adequate period is allowed for the chemical reaction to take place (48 hours approx.). A heating element is not allowed to be detached and reinstalled after it has been installed completely for the first time.

L. The heating elements must not contact any of the seat's electrical conductive components such as hog rings or the seat's frame in any way or you risk the Danger of Short-Circuiting!

M. The heating performance at the cover's surface varies according to the type of seat or cover. Every millimeter of the cover's foam thickness prolongs the heating time by up to 15 seconds.

O. The seat heating unit's function must be explained to the customer and the Operating Instructions Section of this installation guide must be provided. The customer must be informed about all safety aspects. The operating instructions must include the fuse location and its position.

R. The points in the operating instructions must also be followed for the installation.

Pre-Installation Summary – Overview

1. Remove the existing front or rear seat covers.
2. Take note of whether the covers reattach by way of Velcro or Hog rings.
3. The Wire Connector with Purple & Black colored wires is seat the connector which will enable the use of both High & Low temperature functions.
4. Place the heating pads on the seat and at the Listing Reattachment Area mark the pad with a pen. You will be cutting 2 holes per pad. The holes should be equidistant.
Example: If your listing length for Velcro or hog rings is 12' in length then, make a hole at the 4" & 8" point. (The Seat Heaters may also be trimmed in length)
5. Now separate the protective adhesive backing at the backside of the heating pads and carefully align your pad and holes with the listing area and press the pads against the seat foam to secure the pad in place.
6. Reinstalling the Covers:
Tip: For Backrest Covers, turn the cover inside-out and roll the cover back down the backrest, then reattach the plastic clips. For Seat Bottoms, start by attaching your Velcro or hog ring listings and then proceed to work outwards. Don't work from front to back or from left to right – start from the middle then work outwards!
7. **Switch Location:** The diameter of the hole for the switch is 13/16" or 21mm & the most common location for the switch is on the plastic trim located at the side of the seat.
8. **Power Sources:** The most common sources are the Accessory Panel, Power Seat, Cigarette Lighter/Accessory Outlet, and Steering Column. However, we recommend drawing power via a relayed keystack trigger sourced directly from the battery. This avoids onboard electronic system interference.

*** Warning ***

If you are installing seat heaters into a vehicle which has a Passenger Side Occupancy Detection System for the Air Bags , You Must Observe The Following: When you remove the seat bottom seat covers, identify whether or not the seat is equipped with topside sensors. They are usually visible and resemble flat circular disks which are interconnected or rectangular in shape. If you are uncertain, you must contact a service department professional for confirmation.

Toyota, Kia and Hyundai usually locate the sensors on top of the seat bottom core foam.
Honda usually locates the sensors on the face of the seat backrest.

In either case, for that particular seat (usually passenger sides only) use only the 2-temp wire connector with one of our seat heater pads. (Disconnect one of the other pads – you will not need it)

*The dual temperature wire connector is attached to a black and a purple wire. This will allow dual temperature function with the use of only a single pad.

Do as the factory does!!

When you purchase a Toyota Sienna from the factory they only heat the passenger side backrest. The Seat Bottom has NO Heat.

When you purchase a Honda Odyssey from the factory they only heat the passenger seat bottom. The Backrest has NO Heat.

*** Reminder ***

Whenever a cover is removed and reinstalled Please have the Dealership Service Department Recalibrate the Seat Sensor to Register "0" –Zero!!

Installation Instructions

1. Ensure that the vehicle is on a level surface in "Park" & with the hand brake engaged.
2. Disconnect the car's battery or ensure that the work area is well grounded.
3. Unplug any wires which may be attached / harnessed to the underside of the vehicle's seat. Proceed to unbolt the seat from the vehicle's floor.
4. Carefully remove the seat out of the vehicle to allow for easier access to the vehicle's seat & seat cover trim "J" clips.
5. Carefully remove the seat covers off of the seat by detaching the "J" clips which bind the Backrest Cover together. Then, detach the clips which secure the seat bottom seat cover. These clips secure the cover at the base / perimeter at the bottom of the seat.
6. Place the heating pad & the seat bottom heating pad against the respective backrest & seat bottom. Align the heating pads against the seat & "Mark" the listing attachment area to be cut to allow for the re-installation of the backrest & Cushion covers.
7. If required, carefully cut no more than 2 holes horizontally or 2 holes vertically from each of the seat heater pads. The diameter of the each hole should not exceed 1 inch.
NOTE - The seat heater pads may also be trimmed in length to accommodate a variety of seating styles & listing locations.
Example - If the seat bottom pad length is too long then simply trim the heating pad with a pair of scissors to achieve the desired length
Do Not - Cut the heating pads widthwise!!! This will render the seat heater useless and void the warranty.
8. Remove the protective backing from the back side of the seat heating pad and carefully adhere the pad to the seat at the desired location.
9. At this point the holes cut in the pad should align with your identified key listing attachment locations.
Note - Older style listings = wire rod and listing sleeve (requires hog rings for the installation). Newer style listings incorporate Velcro attachments. For older styles listings secure one of the provided strips of adhesive tape around wire listing rod to insulate it. the
10. Locate an onboard power source that is able to deliver a continuous 10 Amp current. This source may be located at your accessory panel, accessory outlet, etc. Consult with the Owner's Vehicle Manual to ensure an appropriate location as a source of power source.
11. Once the power source is located extend the wiring harness underneath the carpeting to be able to access this power source. (Never install the wire directly under where the occupant's feet would rest)
12. Find a suitable location for your seat heater switches either at the side of the seat, front dash or floor mounted center console in between the driver and passenger seats.
13. At the desired location drill a 13/16" or 21mm hole and pull the main wiring connector to be attached to the seat heater switch harness connector through the hole. Attach the switch connector with the main wiring connector and push everything back through the hole and make sure to push the switch snugly into the hole until you hear a "click".
14. Re-install the vehicle's seats and attach the connector which you secured underneath the seat with the connector pulled up through the carpeting. Make sure to securely rebolt the vehicle's seats to the vehicle's floor.
15. At this point connect the seat heater lead wires to the previously identified safe power source and secure a good ground base.
16. Make sure to connect your battery terminals and start your ignition.
17. Press the seat heater switch to the upward position for a desired high setting. The middle setting is the Neutral or "OFF" position. Press the switch down to the lower position to engage the Low temperature setting.
Caution - If at any time you feel that the seat heaters are too hot or causing dizziness due to overheating please turn off the seat heater and / or take your vehicle to the side of the road and carefully exit the vehicle and wait to regain composure. If you feel that the seat heaters are malfunctioning please consult with your Professional Installer.

Wiring diagram

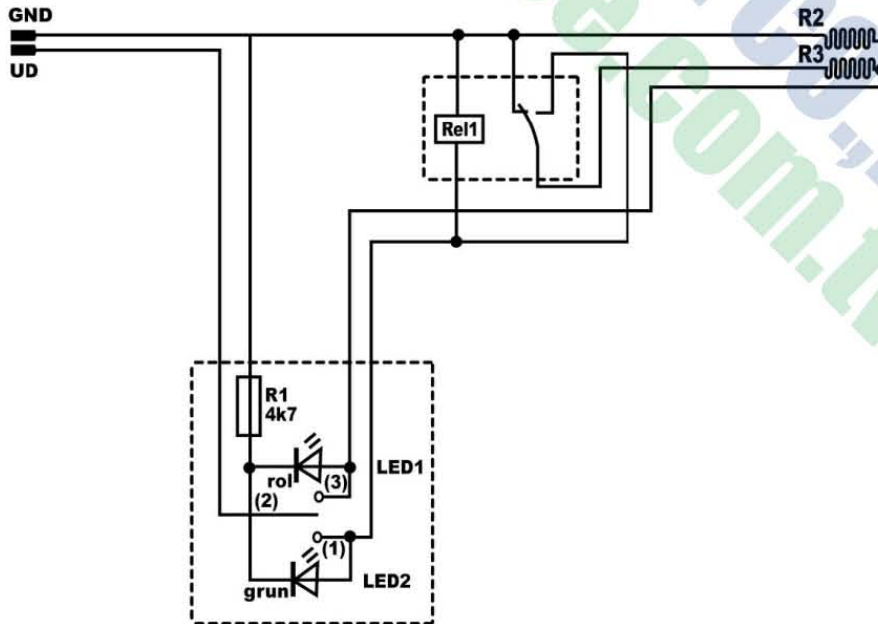
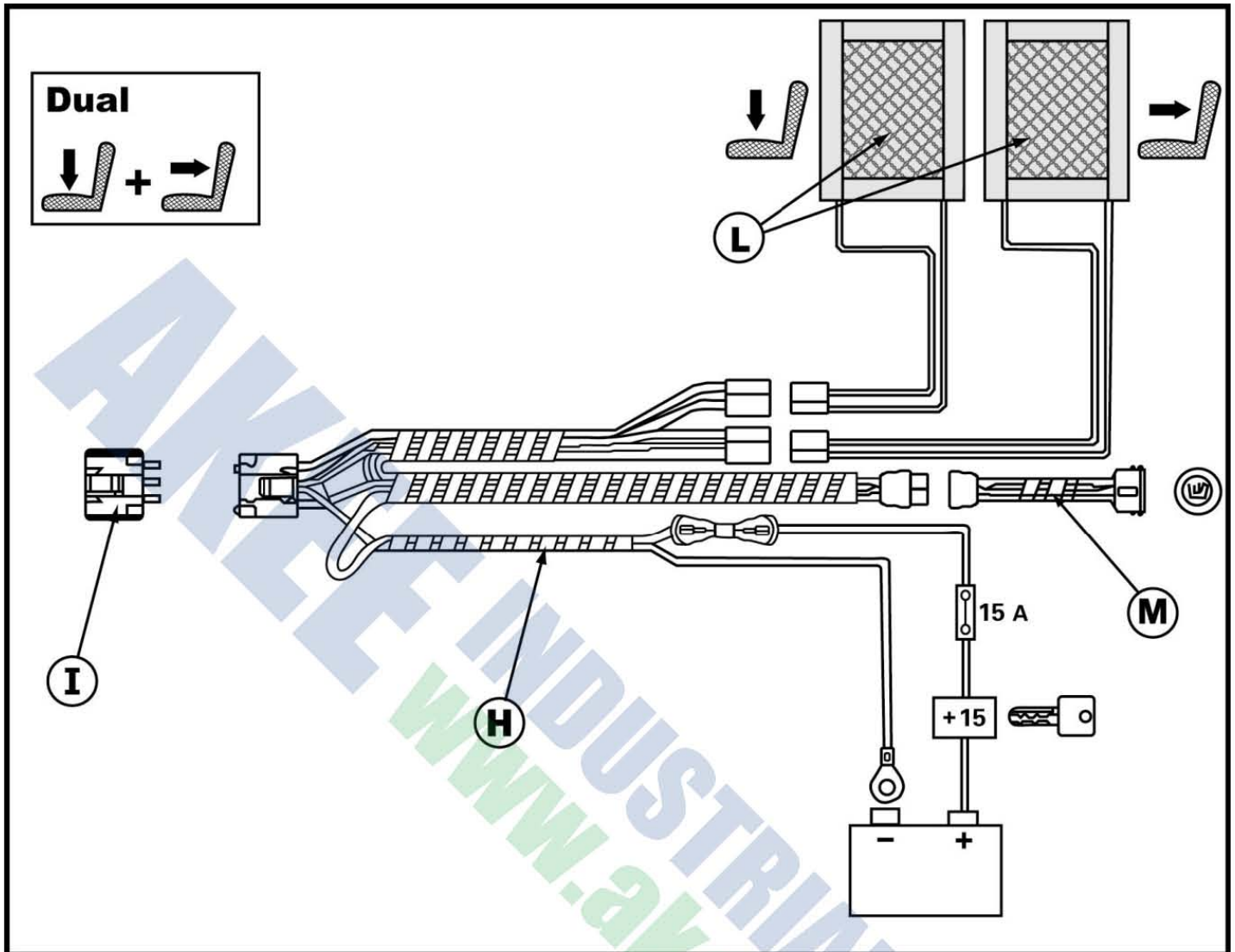

Operating instructions for seat heating units

The seat heating unit is only allowed to be operated when a person is sitting on it. This person must be able to feel temperatures and be able to react to them. Persons who experience difficulty with feeling temperatures – such as all paraplegic persons, children and old people – are not allowed to use the seat heating unit because there is a risk that they will suffer injury from burns.

The seat heating unit, like any other heating appliance, should not be switched on and left unsupervised. Caution is to be exercised when near the seat heater switch as to avoid unintentional activation of the seat heating unit.

A) If the seat occupant feels an excessive temperature after the seat heating unit has been switched on, change to a lower temperature setting to reduce heat or switch off completely.

B) The heating elements are not allowed to come into contact with sharp metal objects such as knives or tools, or any object which could penetrate and pierce the seat's surface and heating elements.

C) The "high" setting of the Seat heater is unsuitable for continuous operation. At the time of installation, the seat heater should not generate heat when vehicle ignition is off.

D) The recommended location of the seat heater fuse is within 12" of the tapped power source. Location of Fuse – for customer reference: _____

E) The seat heating unit must be switched off after the engine has been switched off. This applies if the installer has sourced power from a continuous duty plus circuit, and avoids draining the battery.

F) Sharp objects are not allowed to be transported or put down on the seat. Excessive weights or heavy objects that are put down on the seat can cause damage to the seat heating unit and affect its operation adversely. It is therefore recommended not to put objects on the seat.

G) If an unusual smell develops when the seat heating unit is switched on or if there is an uneven distribution of heat on the seat or backrest – or between the seat and backrest as the case may be – then the seat heating unit must be switched off immediately and a professional installation center must be contacted. The seat heating unit is only allowed to be modified or decommissioned by a professional installation center.

H) When a seat heater has been switched "on", the seat is not allowed to be covered with insulating materials (including blankets or rugs, jackets, cushions, bags, handbags, retro-fitted seat mats, children's seats, seat reinforcement, protective covers, etc.). The seat heating unit's function could be affected if it is operated when these materials are present: this could risk damage to the seat or burning injuries to seat occupant.

I) The seat heating unit is not allowed to be exposed to excessive moisture. Small amounts of the following liquids do not adversely affect the seat heating unit from being operated safely and continuously after it has dried out: perspiration, beverages (e.g., coffee, cola, mineral water, etc.), brine (Saltwater - 5 % in solution), cleaning agents containing ammonia (10 % by volume), cleaning agents containing alcohol (10 % by volume), cleaning agents for plastic or vinyl, or even soap water.

J) Warning: Excessive contact with the any liquids can adversely affect the performance of the seat heating unit and reduce its service life.

The seat heating element must not be turned on at any time when excessive moisture has dampened the seat surface or internal components, or both. The seat heating element must not be operated when the occupant is wearing articles of clothing which is wet or moist. The seat heating element is not to be used for drying clothing or objects.

Operating instructions for seat heating units

Consumer Guide

HIGH Temperature Setting:

- The seat heating system is switched 'ON' by pressing the switch upwards towards the Double wave located at the top of the face of the switch.

I) This will engage the seat heater in the High temperature setting.

II) This is confirmed by the RED color emitted by the LED light.

LOW Temperature Setting:

- The seat heating system is also switched 'ON' by pressing the switch downwards towards the Single wave located at the bottom of the face of the switch.

I) This will engage the seat heater in the Low temperature setting.

II) This is confirmed by the AMBER color emitted by the LED light.

Note:

I) The seat heating element is switched "ON" by moving the switch upwards or downwards from its center OFF position.

II) The heating time can vary according to the type of seat cover material and kind of clothing or coat that is being worn. The heating must be switched to the 'Low' setting in order to avoid overheating, when the desired temperature has been achieved.

Caution:

The heat will be noticeable within 4 - 5 minutes. The heating must be switched off in order to avoid overheating, whenever the temperature is too high.

Troubleshooting:

The Heating does not function although it is switched on. The LED is not illuminated.	Verify the fuse is okay and change it if necessary. Consult a Professional Installer if the fuse is in order.
The LED is not illuminated although the heating is functioning and switched ON.	The LED in the switch is defective
The Heating does not function although it is switched on. The LED is ON.	The temperature of the seat cover may be too high due to the high interior temperature of the vehicle. The thermostat in the seat heater is connected. Wait until the seat cover's temperature has fallen and try again.
The distribution of heat in the seat or back is uneven.	Switch off the seat heating unit and Consult a Professional Installation Center.
The fuse burns out repeatedly.	Check the fuse rating. Consult a Professional Installation Center if the fuse rating is correct.